

Lean Six Sigma Analysis to Improve Space Shuttle Orbiter Tile Removal and Replacement Process

Vertical

- Manufacturing
- Pharmaceutical
- Healthcare
- Portfolio
- Logistics
- Financial
- Government**
- Business

Genre

- Case Study
- Project Review:**
- White Paper
- Technology Overview

Client

United Space Alliance



Situation

United Space Alliance (USA) is the prime contractor to NASA for space flight operations, responsible for all space shuttle fleet and all international space shuttle processing operations.

One of the key components of the outer surface of the shuttle orbiter is the tile. An orbiter tile is a quartz fiber block with silica coating. The tiles provide thermal protection for the orbiter's skin during ascent and re-entry. Tiles need to be removed and replaced for a variety of reasons including:

- *Damage during launch and landing*
- *Modifications to the vehicle*
- *Access to other systems*

The process to remove and replace tiles was identified as one which needed to be improved due to the following:

- *High scrap rate*
- *Long cycle time*
- *Limited resources*
- *Increased volume expected to support Orbiter Major Modifications (OMM)*

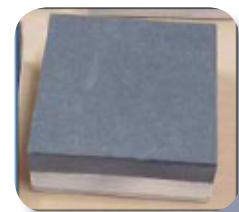

New Tile



Damaged Tile

Objective

Utilize Lean Six Sigma methods to analyze and improve the tile removal and replacement process.

Results

The results, summarized in the chart below, were achieved through combining Lean Six Sigma methodology and simulation technology.

<i>Performance Measure</i>	<i>Predicted Results</i>	<i>Actual Results</i>
Cycle Time	25% Reduction	To be determined
Process Cycle Efficiency	25% Improvement	To be determined
Pattern Rework Rate	8% Reduction	8.1% Reduction
Tile Scrap Rate	50% Reduction	54% Reduction
Post Tile Bond Rework	25% Reduction	To be determined

The predicted results were generated by simulating the process changes identified through Lean Six Sigma analyses. The actual results were measured by USA during execution of the redesigned process.

ProModel Simulation of Tile Removal & Replacement Process Map

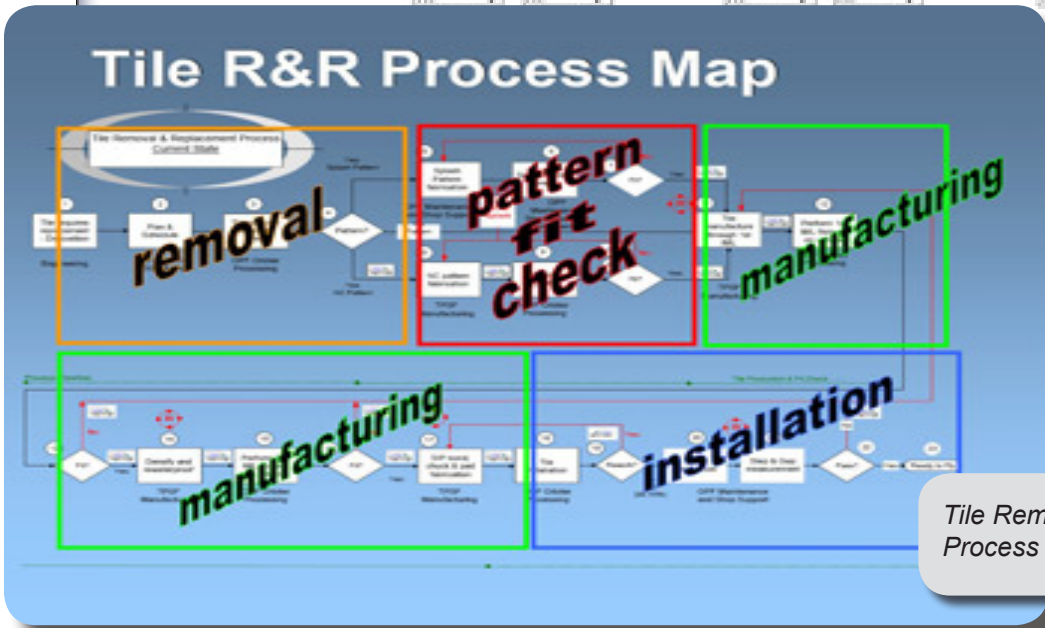
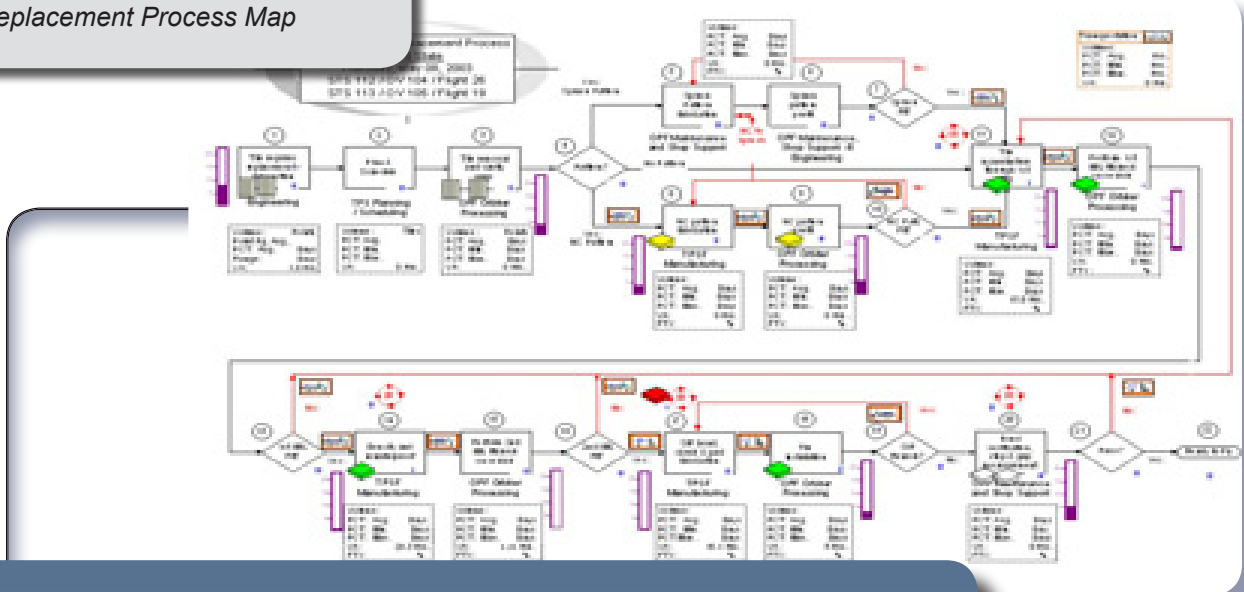

Tile Removal & Replacement Process Map

Solution

USA's Processing and Manufacturing Group developed a solution which utilized a combination of Lean Six Sigma methods and simulation technology to help Visualize, Analyze, and Optimize the Tile Removal & Replacement process. ProModel's ProcessSimulator, a plug-in to Microsoft's Visio, was utilized because of its capability to simulate process maps and complement the Lean Six Sigma methodology.

"Process simulation is a vital core tool in our Lean Six Sigma Team process improvement efforts. USA is using ProModel simulations to help reduce cycle times, predict resource needs, determine work completion dates, justify electronic systems, and improve overall process performance. USA has also used simulations in the past to optimize shop layouts, determine production capacity, and identify shift and equipment utilization in a number of key areas."

- Project Leader in the Processing & Manufacturing Group at United Space Alliance located at the Kennedy Space Center in Florida